

Electrodynamic transduction

ERIC BAVU, MARC PACHEBAT ET GUILLAUME PENELET

Table des matières



| | |
|--|-----------|
| Objectifs | 5 |
| I - Elementary phenomena | 7 |
| A. An academic experiment..... | 7 |
| B. Laplace force..... | 8 |
| 1. <i>The phenomena</i> | 8 |
| 2. <i>Direction and orientation of the Laplace force</i> | 8 |
| C. Lenz law: the phenomena..... | 9 |
| D. Coupling in the harmonic domain..... | 10 |
| 1. <i>Electromotive force vs counter electromotive force?</i> | 10 |
| 2. <i>Oscillatory domain (1/2)</i> | 10 |
| 3. <i>Oscillatory domain (2/2)</i> | 10 |
| E. What if we replace the rod with a membrane? The electrodynamic ribbon driver. | 11 |
| II - Axisymmetrical geometry | 13 |
| A. How to make a transducer more compact?..... | 13 |
| B. The moving coil electrodynamic loudspeaker..... | 14 |
| 1. <i>Structure of a moving coil loudspeaker</i> | 14 |
| 2. <i>The loudspeaker as a generator (1/2)</i> | 17 |
| 3. <i>The loudspeaker as a generator (2/2)</i> | 17 |
| 4. <i>The loudspeaker as a sensor</i> | 17 |
| C. Coupling equations of an electrodynamic loudspeaker..... | 18 |
| III - Equivalent electrical representation | 19 |
| A. Equivalent network using a transformer..... | 19 |
| B. Equivalent network using a gyrator..... | 20 |
| IV - Bibliography | 21 |
| V - Exit test: test your knowledge | 23 |
| VI - Exit test (answers) | 25 |

Objectifs

The objectives of this section are:

- to present the **physical phenomena** responsible for electrodynamic transduction, without detailing the electroacoustic foundations on which the phenomena is based;
- to describe the phenomena through **coupling equations** linking the electrical quantities (U, i) to the mechanical ones (F, v);
- to express these coupling equations in the form of equivalent electrical circuits.

The preredquired notion relative to this section are:

- some notions in electromagnetics (a complete comprehension of this vast domain, is not mandatory however),
- modules 1 and 2 of this lecture.

Elementary phenomena



| | |
|--|----|
| An academic experiment | 7 |
| Laplace force | 8 |
| Lenz law: the phenomena | 9 |
| Coupling in the harmonic domain | 10 |
| What if we replace the rod with a membrane? The electrodynamic ribbon driver | 11 |

A. An academic experiment

Consider the system shown in the following image, composed of a conductive rod which can roll along the axis \vec{x} . A U shaped magnet is placed between the two rails so as to keep the rod in a constant magnetic field \vec{B} whose direction is $-\vec{z}$.

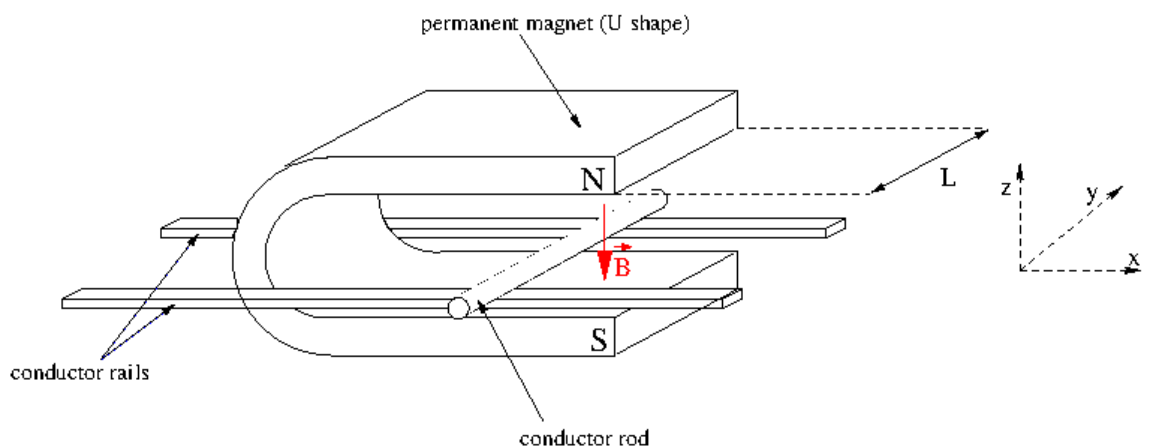

This is an electromagnetic transduction system that can function as either a generator (moving the rod along the rails will cause a current to circulate through the system) or as a receiver (the rod begins to rotate due to the electrical current flowing through it).

B. Laplace force

1. The phenomena

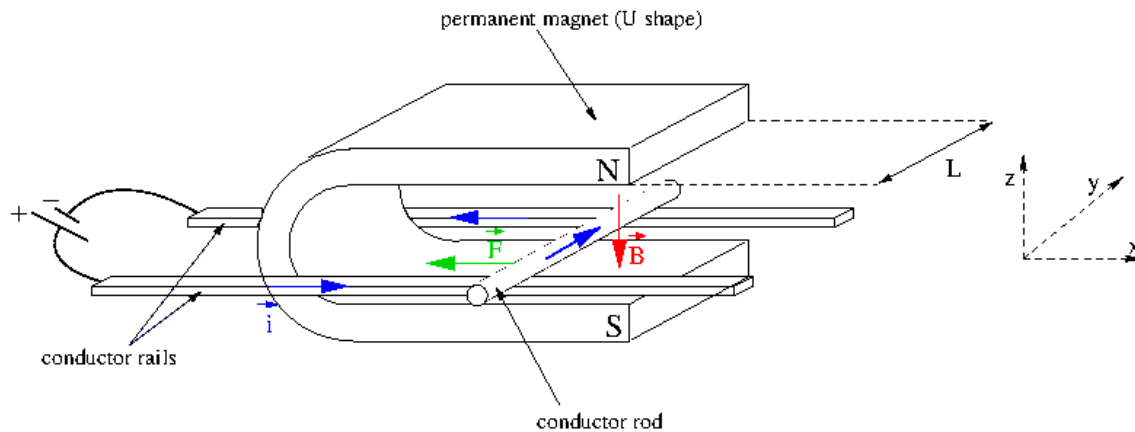

- Firstly, we consider that an electrical current is flowing through the conductive rod \vec{i} . Under the effects of the magnetic field \vec{B} and electrical current \vec{i} , an electromotive force \vec{F}_{em} is applied to the rod.
- The amplitude of this movement depends on that of the current \vec{i} , magnetic field \vec{B} , and the length of the rod ℓ . The movement \vec{F}_{em} is orientated so that the three vectors \vec{i} , \vec{B} and \vec{F}_{em} make up a direct orthogonal basis: $\vec{F}_{em} = \ell \vec{i} \times \vec{B}$, where \times represents the vector product.
- Hence, the consequence of the Laplace force is the movement of the rod. This movement will also be influenced by any other exterior forces applied (friction, elasticity, inertia).

Remark: the length ℓ taken into account is that of the part bathed in the magnetic field. The rod could be twice as long, but if the same magnet is used, the force will be the same.

2. Direction and orientation of the Laplace force

There are three different methods to easily find the direction and orientation of the Laplace force $\vec{F}_{em} = \ell \vec{i} \times \vec{B}$ and notably, "the right hand rule".

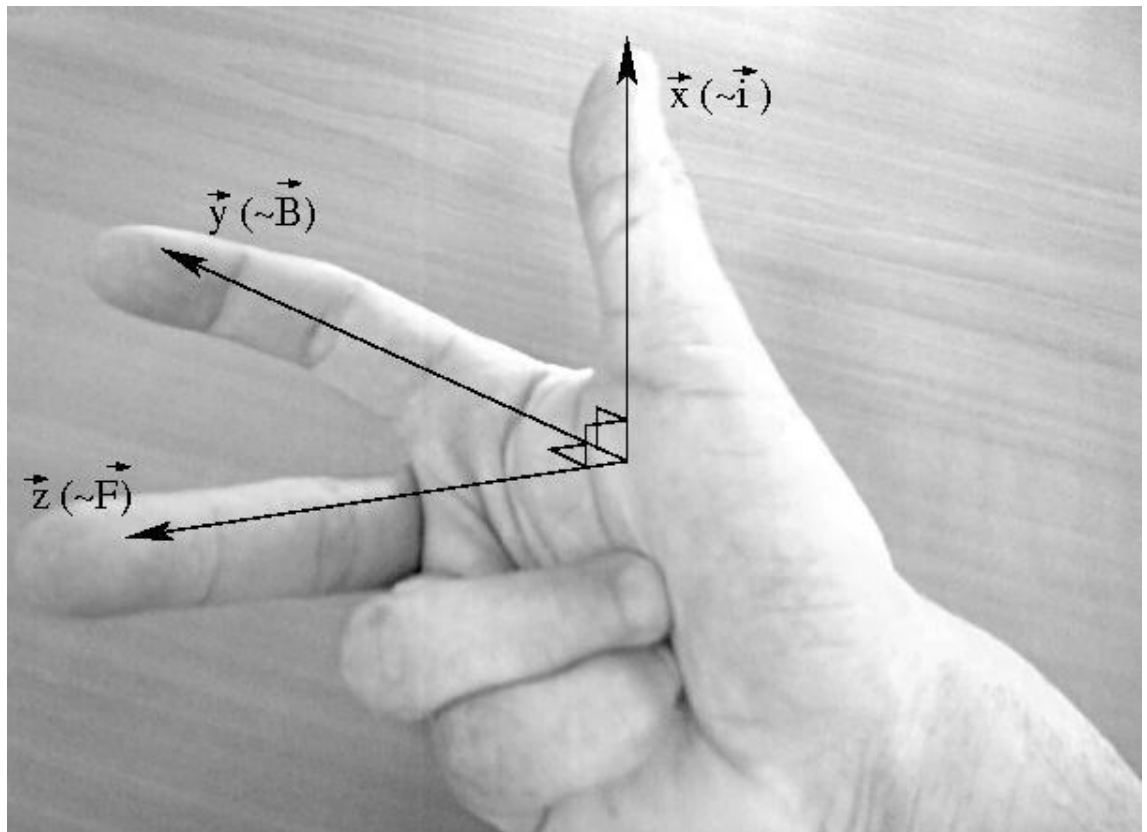

Right hand rule

The thumb and first two fingers of the right hand can be naturally made into an direct orthonormal base.

C. Lenz law: the phenomena

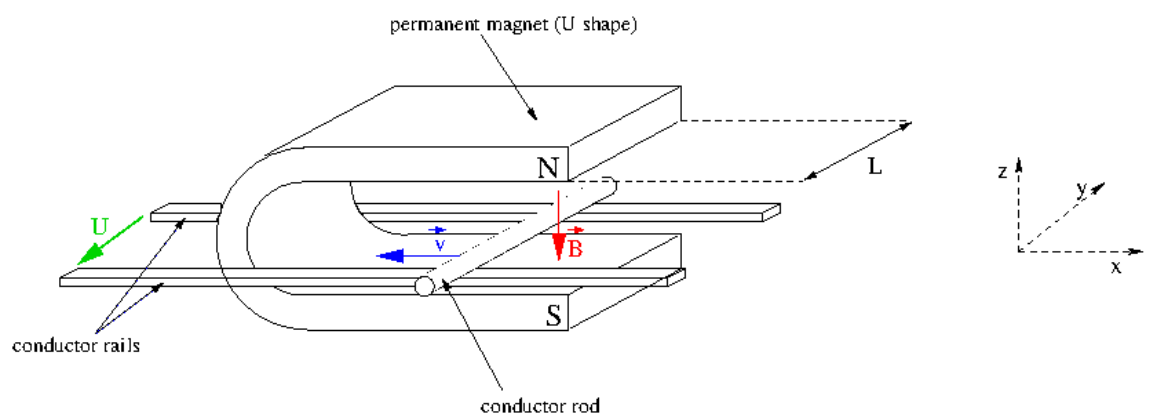

- If we now consider that the rod is moving along the \vec{x} axis under the effect of an exterior force. Under the combined effect of the magnetic field \vec{B} and the speed \vec{v} of the rod, a counter electromotive force U_{cem} is created across the rod.
- The potential is linked to a flux variation ϕ of the magnetic force defined by

$\phi = \iint_S \vec{B} d\vec{S}$. It is written $U_{cem} = -\frac{\partial\phi}{\partial t}$. Knowing that the field \vec{B} is constant, it is the surface through which travel the field \vec{B} which varies over time $dS = \ell dx = \ell v dt$.

- This potential is proportional to the length ℓ of the moving conductor, and the magnitudes of the magnetic field and speed. $U_{cem} = B\ell v$

D. Coupling in the harmonic domain

1. Electromotive force vs counter electromotive force?

- A fundamental point relative to the afore mentioned phenomena, is that they are by nature, **indissociable**. Whenever a length of electrical conductor is bathed in a magnetic field \vec{B} and carries a current \vec{i} , it will be subjected to an electromotive force (amplitude $F_{em} = B\ell i$) which will put it into motion, this movement will generate a voltage (said "**counter electromotive force**") $U_{cem} = B\ell v$ across the conductor **which will counter the force that gave it motion**.
- The two phenomena are therefore **coupled** and responsible for the **reversible** nature of electrodynamic transducers.

2. Oscillatory domain (1/2)

- **What happens when the current is a sine wave?**

The "rod" experiment in the harmonic domain: the system is constructed from two steel rods that act as rails, a copper rod (electrical cable $\varnothing = 2.5$ mm). A commercial U magnet creates the magnetic field (here the model M4181ANK from Eclipse). The two rails are connected to the output of an audio amplifier which receives a sinusoidal input signal at 4 Hz.

3. Oscillatory domain (2/2)

Remark: in the video, we can see a variation in the level indicators (red and green LEDs) of the power amplifier. To understand the source of these variations, we would need to know what they represent (voltage, current or power magnitude for example) and how the amplifier is made. However, we can imagine that

these variations are due to the load "seen" by the amplifier. This load will be affected by the length of the rails in the circuit and also the counter electromotive force generated by the motion of the rod.

The preceding theories are thus valid in the case of alternating mechanical (F , v) and electrical (U , i) quantities. The general coupling equations (vectorial characteristics notwithstanding) can be written:

$$F_{em}(t) = B\ell i(t)$$

$$U_{cem}(t) = B\ell v(t)$$

E. What if we replace the rod with a membrane? The electrodynamic ribbon driver

- By replacing the rod with a conductive membrane, the mechano-acoustical coupling becomes more significant due to the large surface area of the mechanical element (see the section on mechano-acoustical coupling) and a loudspeaker is created.
- This type of loudspeaker (or microphone) is named "ribbon" loudspeaker. However, it is not widely used. The development of electrodynamic transducers has led to the creation of several different and more efficient geometries. These are tougher, and cheaper, but based on the same principles. To the present day, the majority of electrodynamic transducers are based on a geometry of axial symmetry.

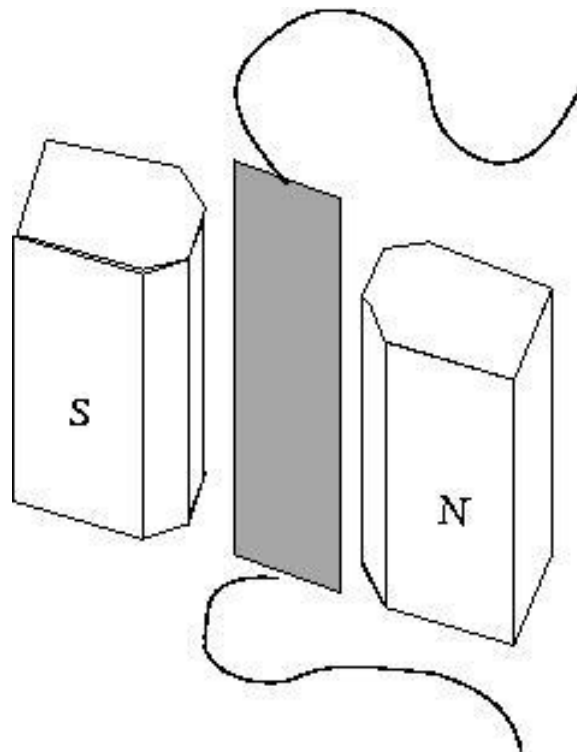

Principle of a ribbon transducer

Axisymmetrical geometry



| | |
|---|----|
| How to make a transducer more compact? | 13 |
| The moving coil electrodynamic loudspeaker | 14 |
| Coupling equations of an electrodynamic loudspeaker | 18 |

A. How to make a transducer more compact?

Radial field and coiled conductors

A way of increasing the transduction efficiency is to increase the length ℓ of the conductor contained in the magnetic field \vec{B} . To maintain a certain compactness, a solution is to wind the conductor into a coil, which in turn means rethinking the spatial distribution of the magnetic field \vec{B} , which should present a radial structure, centered on the coils axis.

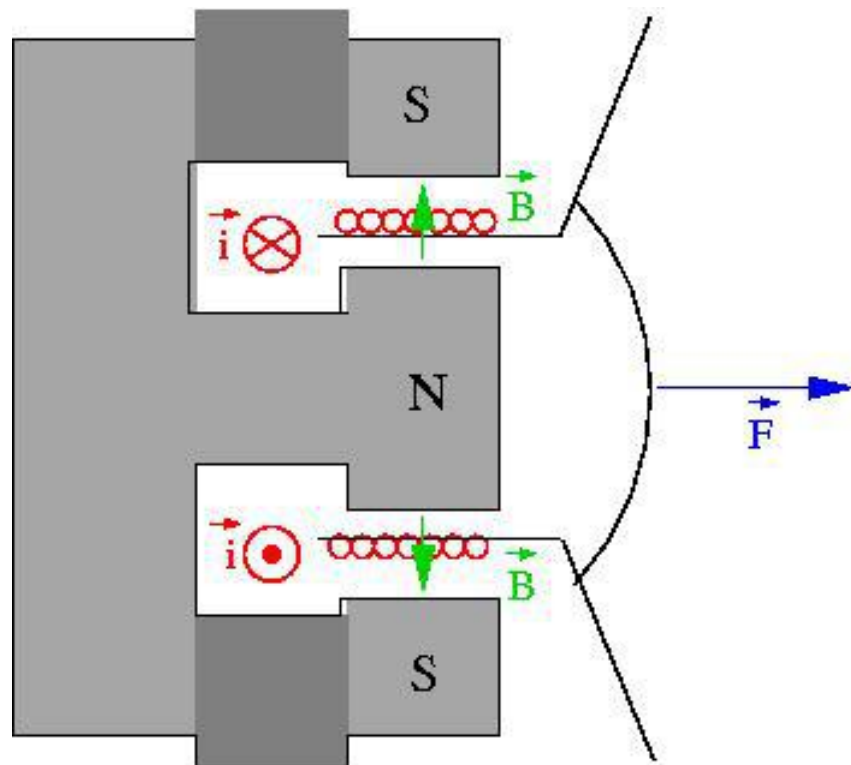

Small exercise: Verify, with the help of the 3 finger rule, that the direction, and orientation of the Lapalce forces shown on the image below are correct.
 $\vec{F}_{em} = \ell \vec{i} \times \vec{B}$ (be careful not to sprain your wrist...).

B. The moving coil electrodynamic loudspeaker

1. Structure of a moving coil loudspeaker

The conventional architecture, dating back to the 1925 patent by Rice & Kellogg, is comprised of a coil attached to a membrane, and placed in a radial magnetic field.

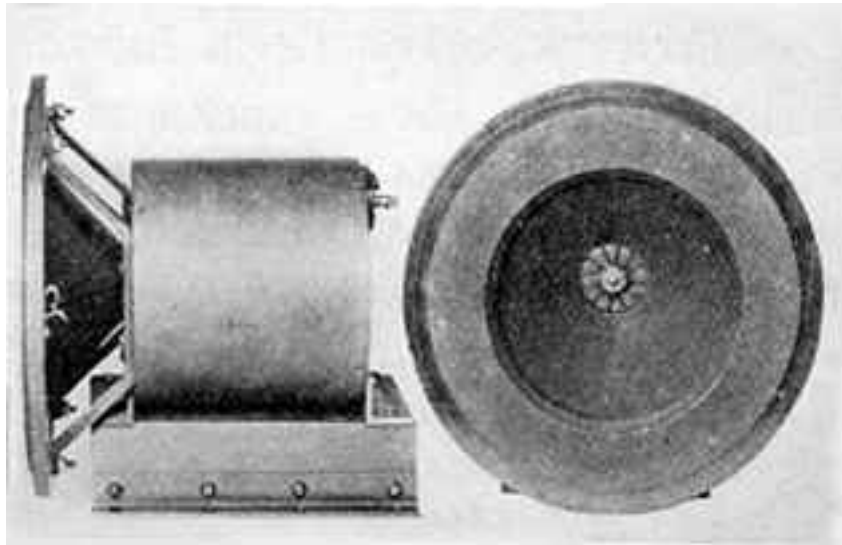

Photography of the patented design from Chester W. Rice and Edward W. Kellogg (brevet No. 1,812,389)

Photographies of a commercial loudspeaker:



Loudspeaker without membrane



Loudspeaker without spider



Coil removed from the motor

2. The loudspeaker as a generator (1/2)

In the following videos, a commercial electrodynamic loudspeaker is connected to a power amplifier with a sinusoidal input of variable frequency. It can be seen that, on one hand the amplitude of the membrane displacement varies with frequency, and on the other (of course), that the radiated sound cannot be heard in the low frequency range (between 5 and 20 Hz).

3. The loudspeaker as a generator (2/2)

Remark 1: it can be seen again, notably during the video of the loudspeaker at 5 Hz, variations in the amplifiers output level (the LED). The interpretation of these variations is the same as the case with the rod.

Remark 2: during the video of the loudspeaker at 20 Hz, beware that the "visible" frequency does not correspond to the real frequency. The number of visible oscillations do not match the real number of oscillations per cycle. This is due to the fact that the image sampling frequency of the camera (a photographic camera in video mode) does not permit a stroboscopic image (under sampling) of the membranes motion.

4. The loudspeaker as a sensor

An electrodynamic loudspeaker is a reversible transducer. It can therefore be used as a sensor (even though it is not optimised for this use). In the following video,

the loudspeaker is connected to an oscilloscope, and a acoustic signal is produced by clapping some hands. An observation of the oscilloscope shows a voltage developed by the loudspeakers coil. An interesting point is the presence of a damped sinusoid after the initial impulse, which is due to the mechanical behaviour of the loudspeaker (free oscillation after an impulse).

C. Coupling equations of an electrodynamic loudspeaker

The coupling equations associated with the electrodynamic transducer come directly from the previous behavioural laws (electromotive force $F = B\ell i$, counter electromotive potential $B\ell v$). The electrical characteristics (resistance and inductance) of the coil must also be taken into account in the coupling equations. We obtain the following system of equations:

$$U - Z_e i = B\ell v$$

$$i = \frac{1}{B\ell} F$$

where

$$Z_e = R_e + jL_e\omega$$

represents the electrical impedance of the coil (resistance R_e , inductance L_e), $B\ell$ represents the "force factor" of the transducer (ℓ representing the unrolled length of the coil, and B the magnetic field in the gap), U represents the complex magnitude of the voltage applied across the coil (without a magnetic field, the counter electromotive potential $B\ell v$ cancels, and we find Ohm's law $U = Z_e i$).

Equivalent electrical representation

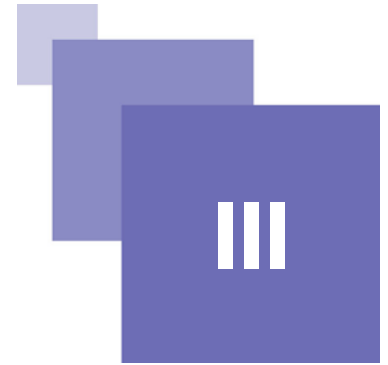

| | |
|--|----|
| Equivalent network using a transformer | 19 |
| Equivalent network using a gyrator | 20 |

A. Equivalent network using a transformer

Coupling matrix

To apply the electrical analogies to the electrodynamic transduction, a two port network that applies the coupling equations must be found. If these equations are rewritten as a matrix,

$$\begin{pmatrix} U - Z_e i \\ i \end{pmatrix} = \begin{pmatrix} B\ell & 0 \\ 0 & \frac{1}{B\ell} \end{pmatrix} \begin{pmatrix} v \\ F \end{pmatrix}$$

a diagonal coupling matrix equivalent to that of the mechano-acoustical coupling appears. This can be represented as an electrical transformer.

Representation by transformer

A possible equivalent electrical representation is that of the below image, a transformer with a ratio of $B\ell$.

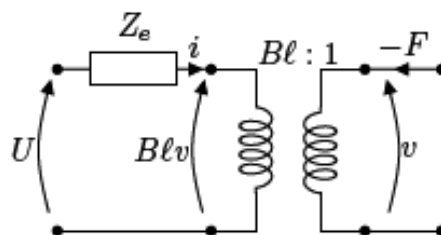

This representation is uncommon, because the same type of analogy cannot be used on either side of the transformer. The variable pair F and v are representation the the admittance analogy (or indirect analogy), the force F represented by a current, and the velocity v by a voltage. Even though it is just a representation of the physical phenomena, the use of a gyrator is preferred to represent electrodynamic transduction.

B. Equivalent network using a gyrator

The representation of the coupling via a gyrator is shown in the following image, where $B\ell : 1$ represents the gyration ratio of the two port network.

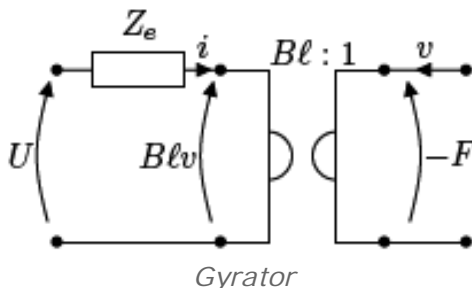

This gyrator, for which there is no associated real linear element, has the advantage that, from an electrical point of view, the mechanical quantities use the direct analogy. As mentioned previously, this is only a convention for the representation. It is more important to remember the coupling equations hidden behind the gyrator, to which is associated the following anti diagonal matrix:

$$\begin{pmatrix} U - Z_e i \\ i \end{pmatrix} = \begin{pmatrix} 0 & B\ell \\ \frac{1}{B\ell} & 0 \end{pmatrix} \begin{pmatrix} F \\ v \end{pmatrix}$$

Bibliography



IV

- M. Rossi, "Audio", chapitre 7, Presse Polytechniques et Universitaires Romandes, 2007. (In french)

Exit test: test your knowledge

V

Question 1

- On the following figure, illustrate the direction and orientation of the electromotive forces applied to the rod.

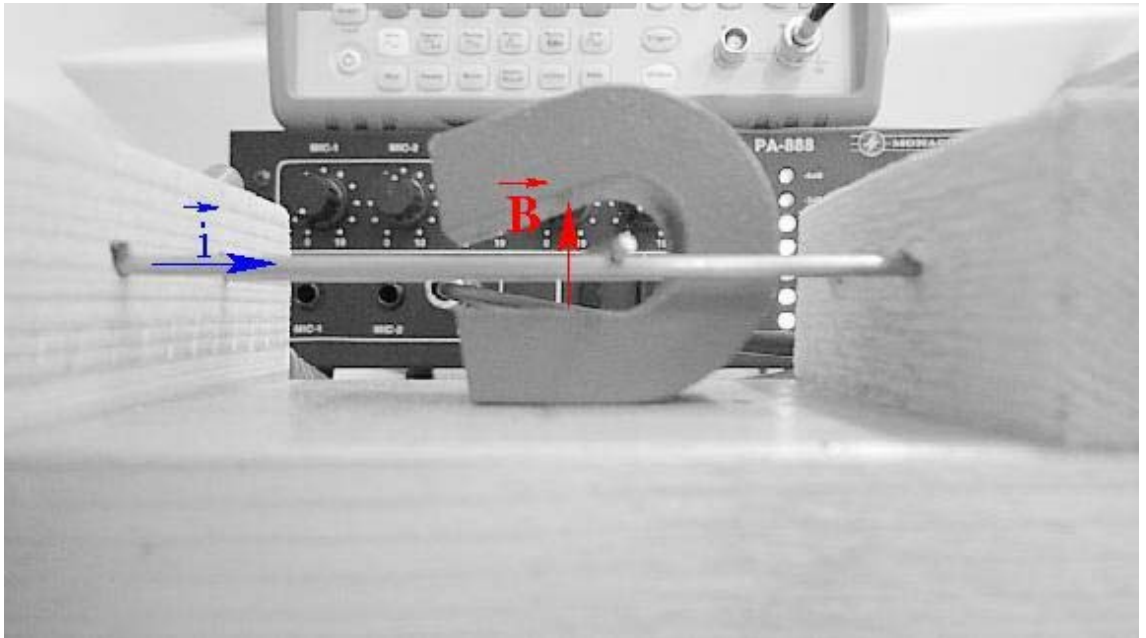

- Knowing that $i = 1A$, $B = 1N.m^{-1}.A^{-1}$ and that the length of the magnet is 1cm, what is the magnitude of the electromotive force F ?
- The copper rod (density: $8960 kg.m^{-3}$) has a diameter of 2,5 mm and a length of 2 cm. What will be the acceleration of the rod under the effect of the electromotive force (the rod moves without friction)?

Question 2

Give the relations between the voltages and currents around the two port network in the following circuit:

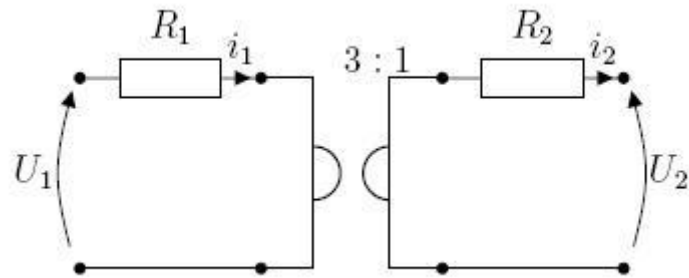

Exit test (answers)

VI

Question 1

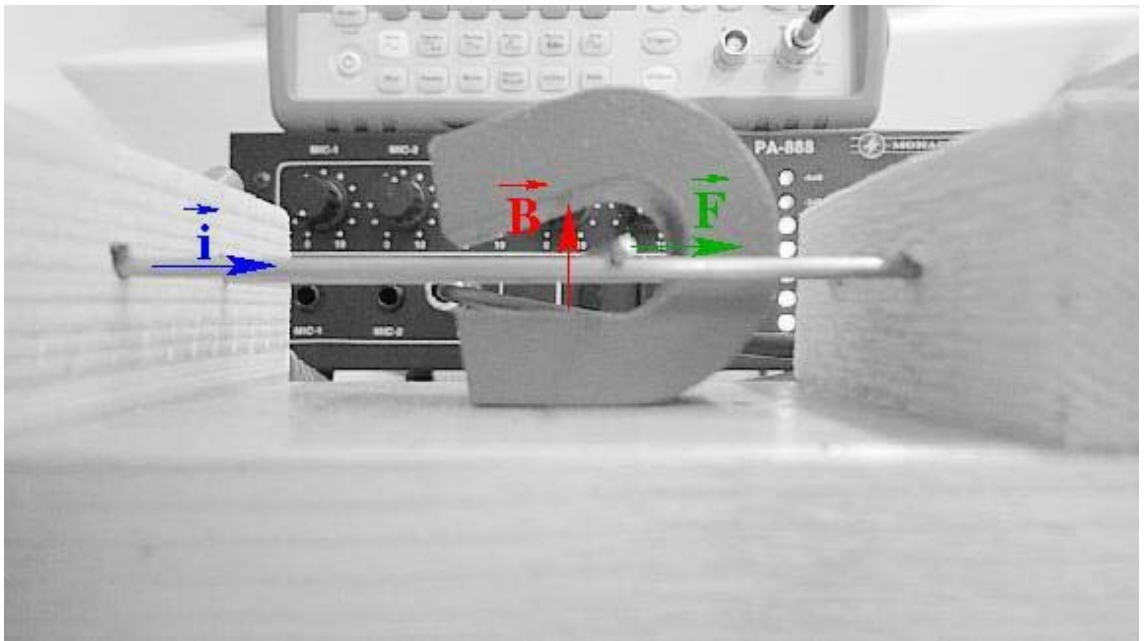

$$F = 10^{-2}N$$
$$a = 11.36m.s^{-2}$$

Question 2

$$U_1 = 3i_2 + R_1i_1 \text{ et } i_1 = \frac{1}{3}(U_2 - R_2i_2)$$